

Space Environmental Viewing and Analysis Network (SEVAN)

**A. Chilingarian, G. Hovsepyan, K. Arakelyan, S. Chilingaryan, V. Danielyan, K. Avakyan,
A. Yeghikyan, A. Reymers, S. Tserunyan.**

Alikhanyan Physics Institute, Yerevan, Armenia, Alikhanyan Brothers 2, Yerevan 375036, Armenia

Abstract

The United Nations Office for Outer Space Affairs and the International Heliophysical Year (IHY) community have joined hands to deploy arrays of small, inexpensive instruments around the world. The small instrument programme is envisioned as a partnership between instrument providers, and instrument hosts in developing countries as one of United Nations Basic Space Science (UNBSS) activity. A network of particle detectors located at middle to low latitudes, SEVAN (Space Environmental Viewing and Analysis Network), aims to improve fundamental research of the particle acceleration in the vicinity of the sun and the space environment. The new type of particle detectors will simultaneously measure changing fluxes of most species of secondary cosmic rays, thus turning into a powerful integrated device used for exploration of solar modulation effects. The first SEVAN modules are under test operation at Aragats Space Environmental Center in Armenia. The network will grow in 2008 by detectors deployed in Croatia, Bulgaria and India. We present the first results of SEVAN module operation as well as a description of the DAQ electronics and software.

1. Introduction

Ground based particle detectors measure time series of secondary particles born in cascades originating in the atmosphere caused by primary ions and solar neutrons. The networks of particle detectors can predict upcoming geomagnetic and radiation storms hours before the arrival of Interplanetary Coronal Mass Ejections (ICMEs) at the ACE and SOHO spacecraft. The less than one hour lead time (the time it takes for the ICME to travel from the spacecraft to the magnetosphere) provided by particle detectors located at ACE and SOHO at the libration point 1,5 million kilometers from the Earth is too brief to take effective mitigating actions to protect satellites and surface industries from the harm of major geomagnetic storms.

To establish a reliable and timely forecasting service, we need to measure, model and compare:

- The time series of neutrons and high energy muons;
- the correlations between changing fluxes of secondary particles; and
- the direction of the detected secondary cosmic rays.

Using our experience (see Chilingarian, et al., 2005; Gevorgyan, et al., 2005; Chilingarian et al., 2003a; Chilingarian, et al., 2003b, Chilingarian et al., 2007, Chilingarian and Reymers, 2007, Bostanjyan et al., 2007) with data analysis of multivariate time-series from ASEC monitors, we designed and fabricated a new-type of particle detector to meet the above goals. In order to keep the instruments inexpensive, the options are kept flexible by using modular designs. The price of a fully autonomous basic detector, with facility to send data to the internet will not exceed \$20,000 US. For this reason the network of countries involved in space research can be significantly expanded, which will facilitate their part in International Heliophysical Year (IHY).

At any time one can add additional similar units to achieve improved functionality; for example, several new observational directions can be added to enhance the accuracy of particle flux measurements. As a world-wide network of neutron monitors (NM, Moraal et al., 2000), the new monitors will measure neutron fluxes and, additionally, charged particle fluxes with different energy thresholds, thus allowing investigation of the additional populations of primary ions. These units will be deployed at universities and research centers of developing countries to perform survey and monitoring of the most dangerous space storms and to involve new generations of students and scientists in space research.

The network is planned to be installed at middle and low latitudes. It will be compatible with the currently operating high-latitude neutron monitor networks “Spaceship Earth” (Kuwabara et al., 2006), coordinated by the Bartol Research Center, the Solar Neutron Telescopes network coordinated by Nagoya University (Tsuchiya et al., 2001), the Muon network coordinated by the group from Shinshu University (Munakata et al., 2000) and the Athens Neutron Monitor Data Processing Center (Mavromichalaki et al., 2005, 2006).

The potential recipients of particle detectors in this new initiative are Croatia, Slovakia, Costa Rica, Bulgaria, Indonesia, and India (see Figure 1 and Table 1). When fully deployed the SEVAN network will provide reliable monitoring of the Sun by at least one detector 22 hours and by two detectors 18 hours every day. We assume that particle fluxes measured by the new network at medium to low latitudes, combined with information from satellites and particle detector networks at high latitudes, will provide experimental evidence on the most energetic processes in the solar system and will constitute an important element of the global space weather monitoring and forecasting service. In the paper we present first results of the SEVAN modules operation at Aragats Space Environmental Center (ASEC) in Armenia and comparisons with simulations reported in our previous paper (Chilingarian & Reymers, 2008). We illustrate the possibilities of the hybrid particle detectors to measure neutral and charged fluxes of secondary cosmic rays, to estimate efficiency and purity of detection and corresponding median energies of the primary proton flux, the ability to distinguish between neutron- and proton-initiated Ground Level Events (GLEs), and some other important properties of hybrid particle detectors.



Figure 1. Possible locations of the Space Environment Viewing and Analysis Network (SEVAN).

Table 1 Geophysical characteristics of possible SEVAN sites.

Station	Latitude	Longitude	Altitude [m]	R_c (GV)
Germany (Greifswald)	54.5N	13.23E	6	2.34
Slovakia (Lomnický štít)	49.2N	20.22E	2634	3.88
Croatia (Zagreb)	45.82N	15.97E	120	4.89
Bulgaria (Musala)	42.1N	23.35E	2430	6.19
Armenia (Aragats1)	40.25N	44.15E	3200	7.1
Armenia (Aragats2)	40.25N	44.15E	2000	7.1
Israel (Hermon)	33.18N	35.47E	2025	10.39
Costa Rica (San Jose)	10.0N	84.0W	1.2	10.99
China (Tibet)	30.11N	90.53E	4300	13.86
India (Delhi)	28.61N	77.23E	239	14.14
Indonesia (Jakarta)	6.11S	106.45E	8	16.03

2. Construction of SEVAN particle detectors

The basic detecting unit of the SEVAN network (see Figure 2) is assembled from standard slabs of $50 \times 50 \times 5 \text{ cm}^3$ plastic scintillators. Between two identical assemblies of $100 \times 100 \times 5 \text{ cm}^3$ scintillators (four standard slabs) are located two $100 \times 100 \times 5 \text{ cm}^3$ lead absorbers and thick $50 \times 50 \times 25 \text{ cm}^3$ scintillator assembly (5 standard slabs). A scintillator light capture cone and Photo Multiplier Tube (PMT) are located on the top, bottom and the intermediate layers of detector. The detailed detector charts with all sizes are available from <http://aragats.am/SEVAN>

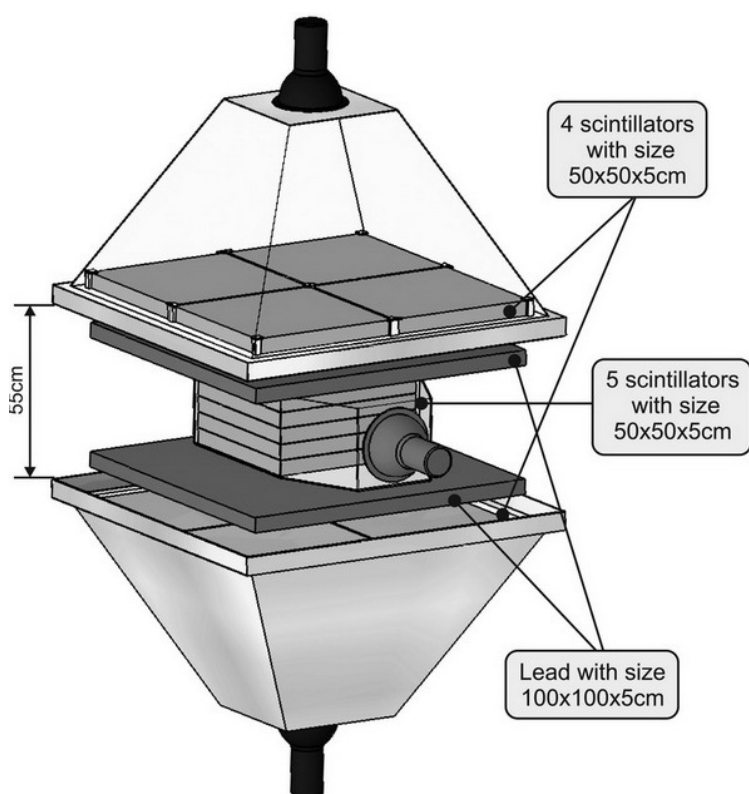

Figure 2 Basic detecting unit of the SEVAN network.

Incoming neutral particles undergo nuclear reactions in the thick 25cm plastic scintillator and produce protons and other charged particles. In the upper 5cm thick scintillator charged particles are registered very effectively; however for the nuclear interactions of neutral particles there is not enough substance. When a neutral particle traverses the top thin (5cm) scintillator, usually no signal is produced. The absence of the signal in the upper scintillators, coinciding with the signal in the middle scintillator, points to neutral particle detection. The coincidence of signals from the top and bottom scintillators indicates the traversal of high energy muons. Lead absorbers improve the efficiency of the neutral flux detection and filtered low energy charged particles. If we denote by “1” the signal from a scintillator and by “0” the absence of a signal, then the following combinations of the 3-layered detector output are possible:

111 and 101 – traversal of high energy muon;

010 – traversal of a neutral particle;

100 – traversal of a low energy charged particle stopped in the scintillator or in the first lead absorber (energy less than ~100 MeV).

110 – traversal of a higher energy charged particle stopped in the second lead absorber.

001 – registration of inclined charged particles

Microcontroller-based Data Acquisition (DAQ) electronics and an Advanced Data Analysis System (ADAS) provide registration and storage of all logical combinations of the detector signals for further off-line analysis and for on-line alerts issuing. The slow control system of the ADAS subsystem allows providing the remote control of the PMT high voltage and important parameters of the DAQ electronics.

3. SEVAN DAQ Electronics

The Data Acquisition electronics (see Figure 3) implementing registration of the charged and neutral fluxes of secondary cosmic rays consists of an 8-Channel Discriminator/Counter Unit (8DCU) and three High Voltage supplies with presetting and automatic control.

8DCU parts are:

- The 8-channel Programmable Threshold Comparator and Counter board (8CNT)
- Universal RS232/RS485 interface/power supply module - IFCC,
- Power transformer - 220V50Hz to 2x8V 0.5A + 2x15V 1.25A

The main features used in 8DCU are:

- 8 programmable threshold analog input,
- Threshold programming range 4mV-1000mV with 4mV step,
- Powered by AC 50-60Hz 220V, 30W
- Maximal counting frequency – 60kHz,
- LEDs to indicate the input pulses in each of 8 channels, module power and programmable trigger condition,
- 8 input BNC connectors,

The 8CNT board is used as a standalone 8-channel counter (scalar) with programmable threshold. For the thresholds programming and the output data readout it can communicate to the host PC (local network) through the IFCC module by any of RS-232 or RS-485 interface ports.

The module counter and interface logic is based on the Atmel AVR Atmega88 8-bit microcontroller.

The DAQ software consists of the host PC program and the microcontroller program (firmware). The firmware for the DAQ and control is written in C language and stored in the microcontroller reprogrammable flash memory. Below is presented the functionality, implemented for the SEVAN detector setup. In this case the microcontroller operates both for the thresholds presetting and control and as a main DAQ controller, with these listed functions:

1. Counting of signals in each of 8 channels,
2. Counting of all types of coincidences of signals in channels 1-3.



Figure 3 8 channel DAQ electronics for SEVAN detector.

The counters' contents are sent out via RS232 or/and RS485 interfaces each second in the format:

```
Cnt1  Cnt2  Cnt3  Cnt4  Cnt5  Cnt6  Cnt7  Cnt8
Co12  Co13  Co23  Co123
<blank line>
```

where CntX – is the count of pulses in channel X in 1 second, CoXY(Z) – is the count of coincidences in channels X, Y. For example, Co12 is a number of coincidences in channels 1 and 2, without signals in channel 3.

The gate for the coincidences registration is in the range 0.6us - 1us. If signals in two channels come with a delay of more than 1us, they are not considered as coincident. The dead time of the counters is 10us.

The data collection time is set by the microcontroller firmware, so any other value can be chosen.

The IFCC interface module has three connections: to the microcontroller, to the RS232 connector (DSUB9F) and to the RS485 connector (DSUB9M). The signals propagate from each of these connections to both of the others. For example:

1. Microcontroller sends a byte to the TXD line. This byte is propagated both through RS232 TXD line and RS485 interface lines with corresponding voltage levels and polarities.
2. Byte is received in the RS485 line. It appears also on the microcontroller RXD line and the RS232 TXD line.
3. Byte received in the RS232 RXD line is transmitted to the microcontroller RXD line and RS485 interface lines.

In this way the IFCC module can operate coupled with a microcontroller.

The power for the PMT High Voltage supplies (15V unregulated, 1.2A max) is supplied from the 8DCU through the RS485 interface connector.

4. Advanced Data Acquisition System for SEVAN (ADAS for SEVAN = ADASS)

4.1. Unified Readout and Control Server (URCS)

The ADAS (Chilingaryan, 2006) was developed having in mind the distributed nature of particle detector networks consisting of units not easily accessible world-wide. Therefore, the system is designed for autonomous operation, error recovery and remote management capabilities. To simplify cooperation with research groups and open a way for data integration with other particle detection networks, the intercomponent communication is released on top of high level standards. The new extensible XML based data format is used for the data storage and exchange.

ADASS is constructed from uniform autonomous components providing standard web service based control interfaces, named URCS (Unified Readout and Control Server). The URCS server makes available readout of the experimental data from SEVAN particle detectors and provides detector control and preliminary analysis and distribution of the data to other system components. The URCS server is not dependent on any external information and can operate without connection to the rest of the data acquisition network for a long time.

To prevent information loss the collected data is stored in local data storage and distributed to clients by special automated Web services. This service provides structured access to the

collected data and, therefore, facilitates cooperation with remote system components giving a chance to correlate the obtained data with the data collected by other SEVAN detectors world-wide.

The URCS server provides a set of control interfaces for both detector electronics and URCS software. On the basis of these control interfaces the Web front end provides the operator with a full set of remote management capabilities.

In addition to the URCS servers, the ADASS incorporates alarm services and data storage subsystems running on local file servers. The alarm service is used to issue e-mail notifications about severe conditions of Space Weather or/and electronic failures. The data storage servers periodically inquire of the data from all URCS servers and store it in a database on reliable servers in each of the SEVAN sites. Further, the stored data is analyzed by off-line software and made available for physical analysis by means of the DVIN (Data Visualization Interactive Network, Yeghikyan and Chilingarian, 2005) interface. Figure 4 presents the overall system design, realized at Aragats Space Environmental Center (Chilingarian et al., 2005).

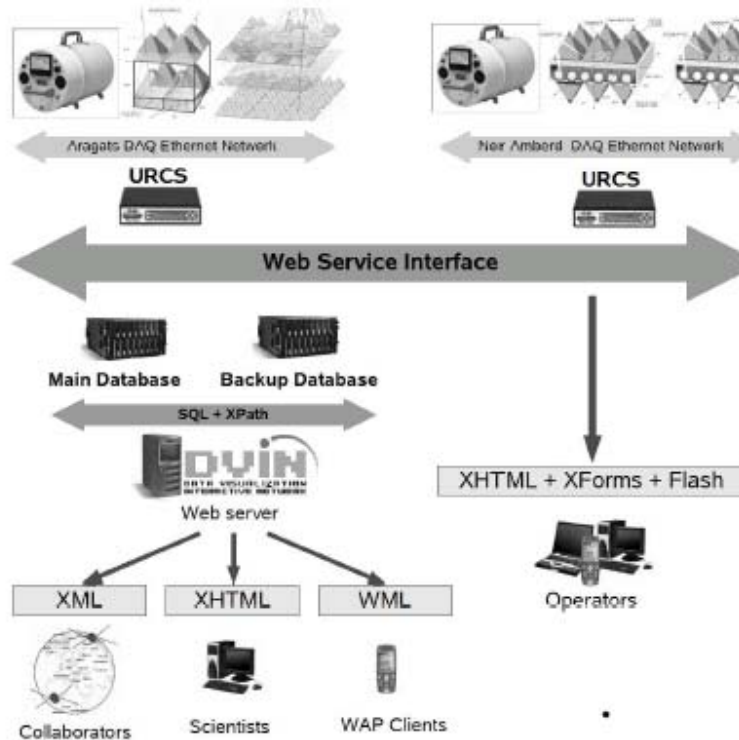

Figure 4 Layout of the new ASEC data acquisition system. Several detector arrays are operating at Nor-Amberd and Aragats research stations. The detectors are controlled by URCS which are installed on each station. The data dissemination and detector control is performed by web services. The DVIN is used to distribute the data to end users.

4.2. Embedded Software

The readout electronics of SEVAN particle monitor is described in the previous section. The embedded software is implemented using double buffer client-server architecture.

At first the devices are initialized in a dummy mode waiting for the control from the host system.

In order to reduce the amount of data transferred between embedded and host systems, the first stage of data processing is performed on the embedded system. The embedded software counts the number of events registered on each of the detector channels as well as coincidences among all three SEVAN channels.

Embedded software expects that the host system will periodically issue requests to retrieve the data. The double buffer architecture is used to relax timing demands. While the current data is prepared in the first buffer, the data of a previous operation is available from the second one upon a driver request. After the data in the first buffer is ready, the buffers are switched. The data consistency is assured using CRC16 checksums carried along with data. Beside data retrieval, the host system may control various parameters of the underlying electronics.

As a part of the startup procedure, the host system passes the desired configuration (channel thresholds, time spans, etc...) to the embedded system, establishes time synchronization and issues an initialization command. On each of the iterations the time synchronization between host and embedded systems is checked. In the case of minor synchronization errors, a time correction procedure is performed. If the error exceeds defined thresholds the embedded system is reinitialized and time synchronization is re-obtained.

4.3. Frontend Computers

In order to improve the system stability we plan on using the Minibox M300 (VIA C7 800MHZ, 1 GB RAM computers based on VIA Eden platform (URL: <http://www.mini-box.com/>). The computers are equipped with a Gentoo Linux-based operating system which is used in conjunction with the 2.6 family Linux kernel optimized for real-time applications. The major advantage of the platform is the complete absence of any moving mechanical parts. The system has passive (fan- less) cooling. Instead of a hard drive, the CF (Compact Flash) memory card is used. A small LCD keypad embedded into the computers is used to represent the current system status, notify operators about critical failures and provides a way for basic system management.

The particle monitors are connected to the frontend computers by means of USB and Ethernet interfaces.

4.4. Unified Readout and Control Server

The URCS (Unified Readout and Control Server) server is a completely autonomous component of the data acquisition network. It operates on the frontend computers and is used for detector control and data readout. It is not dependent on any external information and can operate without connection to the rest of the data acquisition network for a long period of time. To prevent information loss, the collected data is stored on the local Compact Flash card and served to the clients upon requests. The amount of time the data remains stored on the server depends on the detector data bandwidth and may be controlled by the operator.

The URCS server has complex software consisting of multiple interacting components. In the first place it is a URCS daemon - readout software which takes care of communication with the underlying electronics. The communication is performed by means of dedicated drivers while most of the software is the same for all supported detectors. The daemon reads the data from underlying detectors, makes preliminary analysis if necessary, and stores it in the files on the local file system. Furthermore, it hides detector access details from other URCS components providing a uniform way for the detector monitoring and control. The detailed architecture of the URCS daemon is provided in the next section.

4.5. URCS Control Interface

The communication with remote components is carried out by means of web services running on a Apache web server. These web services hide the details of the URCS daemon providing a very simple interface for both the data dissemination and control capabilities to the external world. The data access is well structured. Each underlying particle monitor has its own address space and may provide to the end client one or more independent data sets. The data channels in all data sets are described by metadata properties. These properties may include information on SEVAN sites (names of destination, geographical co-ordinates, altitudes, cut-off rigidities, etc). The set of properties describing all data sets belonging to a certain SEVAN site are collected in the site description and are available to the clients upon a request as well.

The client applications are able to request the latest data from the desired data set or the data for certain historical periods.

4.6. URCS Operator Frontend

The operator web frontend is a URCS component providing a uniform way for the remote control of URCS servers and underlying electronics. By means of the interface the operator is able to perform a full range of monitoring and control operations. It is possible to view various aspects of the current URCS operation, modify actual configurations, start and stop readout daemons or access the URCS log files for the desired period.

The operator is able to browse the data stored on the remote URCS servers. The current data is presented in a fully annotated fashion using associated detector descriptions. The historical data is available in XML, HTML and/or CSV (Comma-Separated Values) forms. The continuous data quality monitoring is feasible by the provided AJAX (Asynchronous JavaScript and XML) interface which is depicting various aspects of the most recent data by means of SVG (Scalar Vector Graphics) charts. Additionally, metadata properties specify special conditions demanding operator intervention. If such a condition is met, the interface will signal an alarm to the operator.

The web frontend is used as well to control the URCS configuration, including configurations of the underlying electronic devices. All system configurations are expressed in XML terms and, therefore, the uniform XForms (XML Forms)-based interface is used to control all detectors and the URCS itself. For each detector only the XForms representation providing mapping between UI (User Interface) elements and XML nodes in configuration is specified. The XForms engine processes user interactions and submits the altered XML configuration to the URCS server.

The URCS server processes global configuration options and passes the individual information for the URCS drivers. To provide XForms functionality in XForms incapable browsers extra application ("FormFaces") is used.

4.7. URCS Installation and Upgrade

The usage of CF (Compact Flash) cards drastically simplifies the software installation and upgrade. The installation can be performed on any computer equipped with CF card reader facility. The installation software asks several questions on the URCS configuration (Name, IP address, Type of Hardware etc.), then installs all required system files, URCS software and configuration files on a provided CF disk.

To upgrade URCS software on the running system it is only necessary to replace the current CF card with a newer one. This operation is very simple and can be performed by the technical staff.

4.8. Detector Network

The URCS daemon communicates with the data acquisition electronics using an Ethernet interface by means of UDP or TCP protocols. The Ethernet segment connecting to the detectors is isolated from the outer world in order to avoid unauthorized access and data corruption. Only a frontend computer running the URCS server is connected to this segment. To obtain the network address the connected devices issue a discovery request by means of the DHCP (Dynamic Host Configuration Protocol). The frontend computer accepts the request and assigns an IP address from the dedicated pool.

Usually, all operating detectors are listed along with their IP addresses in the URCS configuration file. However, it is possible to specify the IP range and default configuration in order to enable the device auto detection. In this case the URCS server will probe all IP's in the range using the discovery command. The identified detectors will be initialized using a specified default configuration.

4.9. Configuration

The operation of a device is controlled by means of an XML configuration. The configuration is initialized from the supported URCS configuration file and mapped into the server memory using a DOM (Document Object Model) representation. The operators are able to adjust the configuration using provided web interface.

The configuration structure is completely device specific. The DOM in-memory is passed to the device driver. It is up to the driver to process configuration and extract required information.

The device configuration consists of several parts. One part is controlling the driver operation. It includes connection properties (type, address, timeouts), a list of writers to use for data storage, properties of the data preprocessing algorithms, etc. Another part controls the detector hardware operation and is passed by the driver to the detector's embedded software.

The configuration structure is described by the XML Schema Description. Both the current configuration and this schema description are used to generate XForms entries providing control interfaces.

4.10. Error Handling

The URCS server allows auto-recovery from system failures. In the case of a hardware failure the problem is logged and the controlling driver performs the hardware re-initialization. Most of possible software problems are handled internally. If a non-recoverable error is encountered the daemon leaves an emergency message in the log. In the last case it would be automatically restarted by a special system daemon which is monitoring the status of all URCS components and restarting them in the case of a detected problem.

4.11. Data Format

To simplify cooperation of SEVAN research groups, to enable data processing automation and to open a way for integration of all SEVAN sites, a new extensible XML based data format is developed for the data storage and exchange.

The ADASS data consists of two components:

- Collected data along with several properties characterizing the data, including the data timestamp, data quality, etc.
- SEVAN site description providing detailed information on the detector location and orientation.

The detector description consists of three main components: Global Detector Description, Detector Geometry and Logical Data Layout. The Global Detector Description provides standard

metadata describing the whole detector. It contains detector name, country, institution, group, principal investigator's contact information, geographical location, etc.

The Detector Geometry describes the detector component parts as well as their positions and dimensions.

The multiple Data Layout sections indicate the physical meaning and acceptable value ranges of the data values. The first two components are preliminary filled during the detector setup and the data layout is automatically generated by the URCS software. Still additional properties may be specified manually on the setup stage.

The data collected by each of the detectors are divided into one or more independent data sets. Each data set is represented as a sequence of data vectors associated with the acquisition time (time series) and one or more Data Layout records in the detector description. The multiple layout records are considered to handle cases when the data set structure is changing during the detector operation. In a way similar to one used by the old data acquisition system at Aragats the data is represented by "space" delimited ASCII strings. These ASCII strings are enclosed in the XML structure providing basic information about the enclosed data and referencing appropriate Data Layout sections of the detector description with the information on the values' meaning.

Example:

```
<Data installation="installationid" layout="layoutid">
  <Time>2006-02-25T16:50:00.000000+04:00</Time>
  <Duration>PT30.000000S</Duration>
  <Quality>100.00</Quality>
  <Value> 12013 3954 5217 0 956 394 828 1488</Value>
</Data>
```

This example illustrates the representation of a single data element by the ADASS format.

The installation and layout attributes reference the appropriate layout in the detector description. The Time and Duration elements indicate the end and duration of the data integration time slice (both the timestamp and duration are represented following the encoding rules defined by the ISO-8601 specification). Special conditions encountered during the data acquisition are described using the Quality element. Usually, this element indicates hardware failures resulting in partly or completely inaccurate data. The Value element holds a data vector in the space delimited ASCII representation.

The data storage subsystem at the file servers downloads the data from the URCS server and stores it in the MySQL database. For each data set a separate table is created and for each attribute and element (installation, layout, Time, Duration, Quality) an individual column is used. All values will be represented by individual columns as well. Such mapping allows easy and fast access to the data, while the original XML form could be easily recovered. The description is not transported together with the collected data but available upon request from the URCS servers. However, the collected data and detector description can be reconciled in a single document for data exchange with collaborating groups.

Using the described approach the legacy application can easily extract ASCII strings from the data set and use them in the old fashion. The new applications are considering the XML description in order to extract the appropriate data subset from the data set.

5. Comparison of modeled and measured SEVAN count rates

At the Nor – Amberd research station of ASEC we are starting tests of the operation of the SEVAN detector prototype with reduced sizes: area of upper and lower 5-cm this scintillators are 0.55 m², instead of 1 m², and thickness of middle detector is 20 cm, instead of 25. In 2008 the

standard SEVAN unit (see detailed charts in <http://aragats.am/SEVAN>) was launched in CRD headquarters in Yerevan. The simulation of the detector response was made in the same way as described in (Chilingarian and Reimers, 2008). The comparison of simulated and measured count rates are presented in **Error! Reference source not found.**

Table 2 Experimental and simulated one-minute count rates by each of 3 scintillators of the SEVAN basic unit located at 3 different altitudes and same latitude and longitude

Location	Yerevan (1000m)		NorAmberd(2000m)*		Aragats(3200m)**	
	Measured count rate	Simulated count rate	Measured count rate	Simulated count rate	Measured count rate	Simulated count rate
Upper Detector All charged particles	13788±134	13109	17109±186	17374	2300±230	26700
Middle Detector	3116±58	3546	3979±62	4591		
Lower Detector	9239±98	9852	9356±132	11755		

*- the upper and lower scintillators of the first SEVAN module located in Nor Amberd have smaller sizes ($0.55 \times 0.55 \text{ m}^2$), therefore we recalculate the count rate to be equivalent to standard 1 m^2 SEVAN module. The coefficients obtained from simulation were for the upper scintillator - 0.5625, for middle – 1, for lower – 0.54

** - the count rate of “anticoincidence shielding” of Aragats Solar Neutron telescope (ASNT)

Each layer of SEVAN module is registering a combination of charged and neutral particles, to “purify” detected fluxes we have to use coincidences of signals also registered by SEVAN. The different combinations of the signals and absence of signals in three layers of the SEVAN detector make it possible to select events enriched by low energy charged secondary particles, neutral particles and high energy muons (Chilingarian and Reimers, 2008). The following combinations are of utmost interest:

- The combination 100 (signal only in upper scintillator) represents the flux of low energy charged particles (mostly electrons and muons) filtered by 5cm of lead below the upper scintillator; energy not greater than $\sim 100 \text{ MeV}$;
- The combination 010 represents the neutral component of secondary cosmic ray fluxes, detected by nuclear interaction in “thick” scintillator, accompanied by generation of charged particles;
- Combinations 111 and 101 represents the traversal of a high energy muon with minimal energy 200 MeV ;
- There exists also “exotic” channels, for example, – “trapping” of muon in lead and creation of a mesoatom – combination 110, but obviously the signal of this effect is hidden by more frequent cases of filtering of a muon by the lower lead filter or by the traversing of a high energy electron through the first lead filter or nuclear interaction of a neutral particle in the upper scintillator with consequent birth of a charged particle cascade reaching the middle scintillator. For revealing the mesoatom cases, we need more precise calculation of the detector response

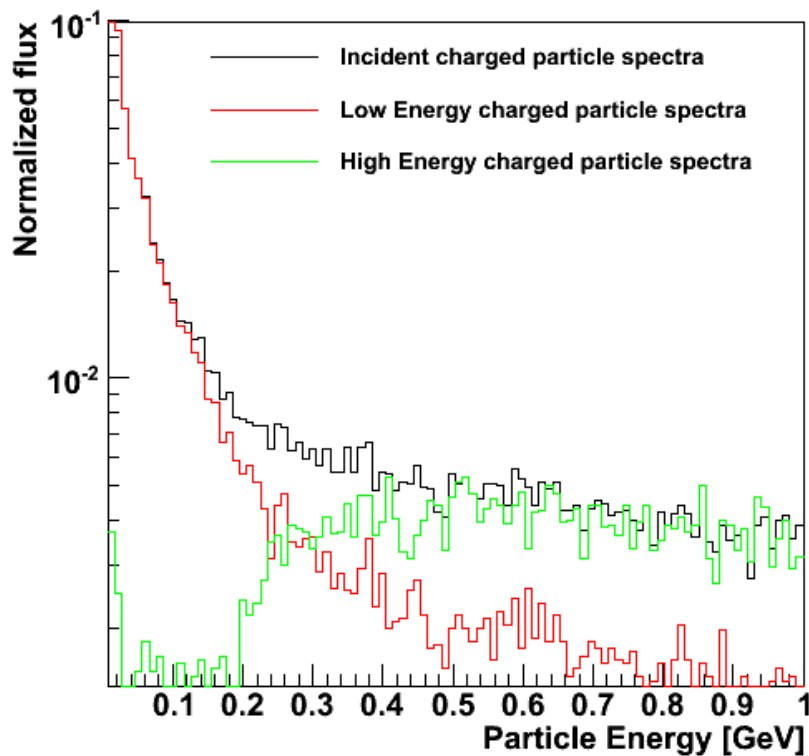

Figure 5 Energy spectra of low and high energy charged particles as measured by first and third layer of SEVAN module (simulation)

In the **Error! Reference source not found.** we present energy spectra of charged cosmic ray flux, as desintagled by the logic of the SEVAN module electronics. The purity of selected events and efficiency of registration were investigated in detail by Chilingarian and Reimers (2008). As we can see in Table 3 the SEVAN module can detect the low energy charged component, neutral component and high energy muons. Low energy charged particles, as well as neutrons and gammas, are attenuated very fast as they penetrate deep in atmosphere. High energy muons did not attenuate so fast as one can see in third row of Table 3.

Table 3 One Minute Count rates of the secondary fluxes detected by SEVAN module.

Type of Secondary particle	Yerevan (1000m)		NorAmberd(2000m)*	
	Measured count rate	Simulated count rate	Measured count rate	Simulated count rate
Low energy charged particles(100)	8862±108	7202	11593±161	10220
Neutral particles (010)	363±19	359	690±27	795
High energy muons (111 &101)	4337±67	5477	4473±99	5548

*- the upper and lower scintillators of the first SEVAN module located in Nor Amberd have smaller sizes ($0.55 \times 0.55 \text{ m}^2$), therefore we recalculate the count rate to be equivalent to standard 1 m^2 SEVAN module. The coefficients obtained from simulation were for the neutral particles – 1; for high energy muons 0.465

With the SEVAN nodule it is possible to detect modulation effects solar activity pose on galactic cosmic rays and magnetosphere, i.e., Forbush decreases and post-Forbush increases of count rate due to coupling of “frozen” magnetic fields in Interplanetary Coronal Mass Ejections (ICMEs). Also it will be possible to detect changes in count rates during the travel of ICMEs from the sun to Earth lasting 17- 50 hours. Modulated counterent species of cosmic rays rates can be used for forecasting of the severity of upcoming Geomagnetic storm. For reliable detection of Ground Level Enhancements (GLEs) additional SEVAN modules will also be needed, because at middle and low altitudes GLEs usually do not exceed 2%. However for extreme events like in 1956, 1989 when the counts can increase 50% even at middle latitudes, GLEs will be reliably detected with one SEVAN module only.

6. Conclusion

Reliable forecasts of major geomagnetic and radiation storms are of great importance because of associated Space Weather conditions leading to failures of space and earth surface based technologies as well as posing radiation hazards on crew and passengers of satellites and aircraft.

Measured solar and interplanetary parameters do not allow for reliable warning on the severity of upcoming radiation and geomagnetic storms (Kane, 2005). Measurements of Solar Wind parameters performed at spacecraft located at L1 provide too short a time span for mitigation actions to be taken. Another piece of valuable information on major storms is provided by networks of particle detectors located at the Earth’s surface.

Networks of particle detectors on Earth’s surface will provide timely information and will be an important element of planetary Space Weather warning services. The big advantage of ground based particle detectors is their consistency, 24 hour coverage, and multi-year operation. In contrast the planned life of the satellites and spacecraft is only a few years, they are affected by the same solar blast that they should alert, and space-born facilities instead of sending warnings are usually set in the stand-by mode.

The multi-particle detectors proposed in the present paper will probe different populations of primary cosmic rays. The basic detector of the SEVAN network is designed to measure fluxes of neutrons and gammas, of low energy charged components and high energy muons. The rich information obtained from the SEVAN network located mostly at low and middle latitudes will allow estimating the energy spectra of the highest energy SCR. The SEVAN network will be sensitive to very weak fluxes of SCR above 10 GeV, a very poorly explored region of the highest energy. To understand the sensitivity of the new type of particle detectors to high energy solar ions we investigate the response of SEVAN basic units to galactic and solar protons. The hard spectra of solar ions at highest energies ($\gamma \sim -4$ to -5 at rigidities ≥ 5 GV) indicate the upcoming very intense solar ion flux with rigidities > 50 MV, very dangerous for satellite electronics and astronauts. The SEVAN network detectors will also allow distinguishing very rare and very important GLEs initiated by primary neutrons.

Summarizing, the hybrid particle detectors, measuring neutral and charged fluxes provide the following advantages over existing detector networks measuring single species of secondary cosmic rays:

- Enlarged statistical accuracy of measurements;
- Probe different populations of primary cosmic rays with rigidities from 7 GV up to 20-30 GV;
- Reconstruct SCR spectra and determine position of the spectral “knees”;
- Classify GLEs in “neutron” or “proton” initiated events;

- Estimate and analyze correlation matrices among different fluxes;
- Significantly enlarge the reliability of Space Weather alerts due to detection of 3 particle fluxes instead of only one in existing neutron monitor and muon telescope world-wide networks.

Construction of the SEVAN network has been started in the framework of the International Heliophysical Year and United Nations Basic Space Science (UNBSS) program focusing on deployment of arrays of small inexpensive instruments around the world (UN, 2006). The Cosmic Ray Division of the Alikhanyan Physics Institute will donate scintillators, photomultipliers and Data Acquisition electronics to donor countries. Installation of the first SEVAN detector abroad is planned in 2008 in Croatia, supported by European Office of Aerospace Research and Development (EOARD). Installation of a SEVAN detector in India is planned late in 2008, and will be supported by the Asian Office of Aerospace Research and Development (AOARD).

Meanwhile several SEVAN detectors are under test at research high-mountain stations on the slopes of Mount Aragats in Armenia.

Acknowledgement:

This work was partly supported by ISTC A1554 grant and EOARD grant FA 8655.

References:

- Bostanjyan, N.Kh., Chilingarian, A.A., Eganov, V.S., et. al.: On the production of highest energy solar protons at 20 January 2005, *Advances in Space Research* 39, 1456–1459, 2007.
- Yeghikyan, A.R, Chilingarian A.A.: Data visualization interactive network for Aragats Space Environmental Center, 2nd International Symposium SEE-2005, Nor-Amberd, Armenia, 245-251, 2005.
- Chilingarian A., Melkumyan L., Hovsepian G., et al.: The Response Function of the Aragats Solar Neutron Telescope, *Nucl. Instr. and Meth. A* 574, 255-263, 2007.
- Chilingarian, A., Reymers, A.: Investigations of the response of hybrid particle detectors for the Space Environmental Viewing and Analysis Network (SEVAN), *Ann. Geophys.*, 26, 249-257, 2008.
- Chilingarian, A.A., Reymers, A.E.: Particle detectors in solar physics and space weather research, *Astropart. Phys.*, *Astropart. Phys.*, 27, 465-472, 2007.
- Chilingarian, A., Arakelya, K. Avakyan, K., et al.: Correlated measurements of secondary cosmic ray fluxes by the Aragats Space – Environmental Center monitors, *Nucl. Instrum. Methods Phys. Res., Sect. A*, 483-496, 2005.
- Chilingarian, A., Avakyan, K., Babayan, V., et al.: Aragats Space – Environmental Center: status and SEP forecasting possibilities, *J. Phys. G: Nucl. Part. Phys.*, Vol. 29, 939 – 952, 2003a.
- Chilingarian, A., Babayan, V., Bostanjyan, N., et al.: Monitoring and forecasting of the geomagnetic and radiation storms during the 23rd solar cycle: Aragats Regional Space Weather Center, *Advances in Space Research*, Vol. 31, 861-865, 2003b.
- Chilingaryan, S.: Universal Data Exchange Solution for Modern Distributed Data Acquisition Systems and it's Implementation for Cosmic Ray Monitor Networks, National Academy of Science, Armenia, Ph.D. thesis, 2006.

- Gevorgyan N., Babayan, V., Chilingarian, A., and Martirosyan, H.: Test alert service against very large SEP events, *Advances in Space Research (ASR)*, Vol. 36, Issue 12, 2351-2356, 2005.
- R.P.Kane, How good is the relationship of solar and interplanetary plasma parameters with geomagnetic storms? (2005), *JGR*, 110, A02213.
- Kuwabara, T., Bieber, J. W., Clem, J., Evenson, P. and Pyle, R.: Development of a ground level enhancement alarm system based upon neutron monitors, *SPACE WEATHER*, VOL. 4, S10001, doi:10.1029/2006SW000223, 2006.
- Mavromichalaki, H., Souvatzoglou, G., Sarlanis, C., et al.: The new Athens center on data processing from the neutron monitor network in real time, *Annales Geophysicae*, 23, 3103–3110, 2005.
- Mavromichalaki, H., Souvatzoglou, G., Sarlanis, C., et al.: Space weather prediction by cosmic rays, *Advances in Space Research*, Volume 37, Issue 6, 1141-114, 2006.
- Moraal, H., Belov, A., Clem, J.M.: Design and co-Ordination of Multi-Station International Neutron Monitor Networks, *Space Science Reviews* 93, 285-303, 2000.
- Munakata, K., Bieber, J.W., Yasue, S., et al.: Precursors of geomagnetic storms observed by the muon detector network, *J. Geophys. Res.* 105, 27457-27468, 2000.
- Tsuchiya, H., Muraki, Y., Masuda, K., et al.: Detection efficiency of a new type of solar neutron detector calibrated by an accelerator neutron beam, *Nucl. Instrum. Methods Phys. Res., Sect. A* 463, 183 – 193, 2001.
- United Nations, Comprehensive overview on the worldwide organization of the International Heliophysical Year 2007, Office for Outer Space affairs, UN office at Vienna, p.44, 2006.